

Oct. 30, 1951

C. L. FENDER
COMBINATION BRIDGE AND PICKUP ASSEMBLY
FOR STRING INSTRUMENTS
Filed Jan. 13, 1950

2,573,254

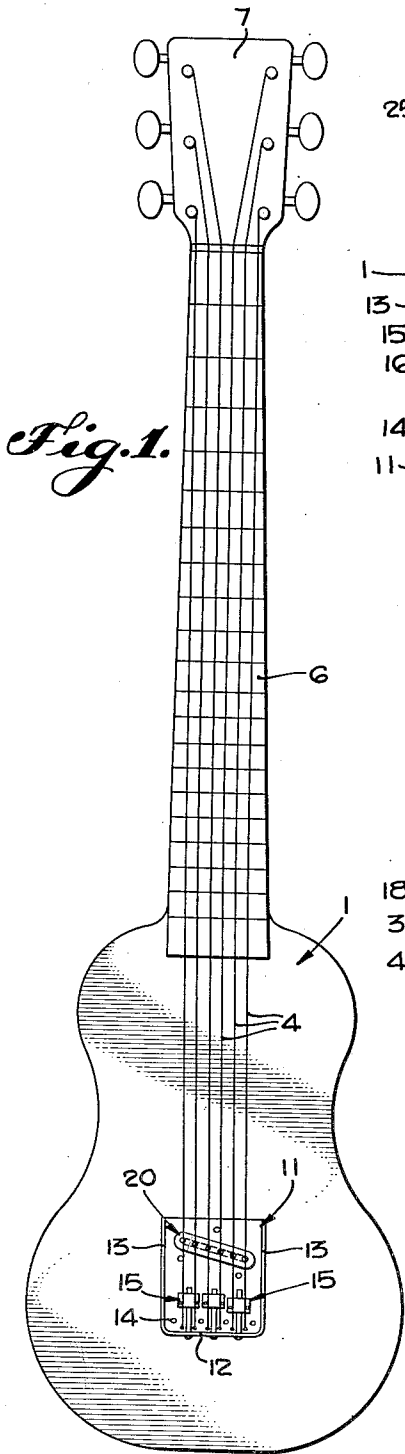

Fig. 1.

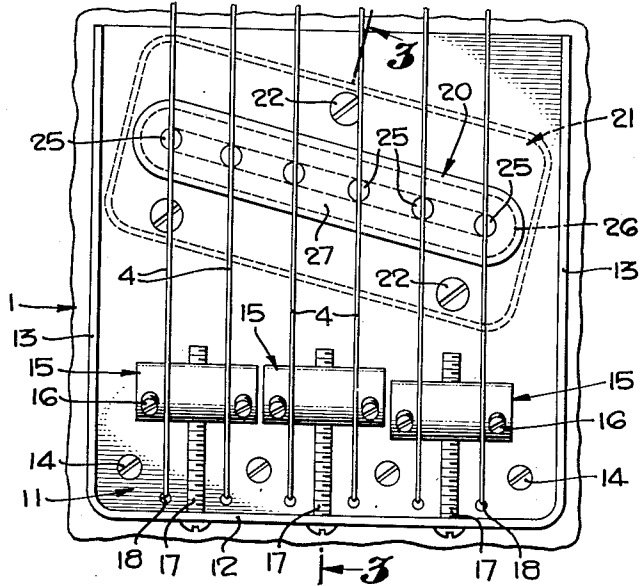

Fig. 2.

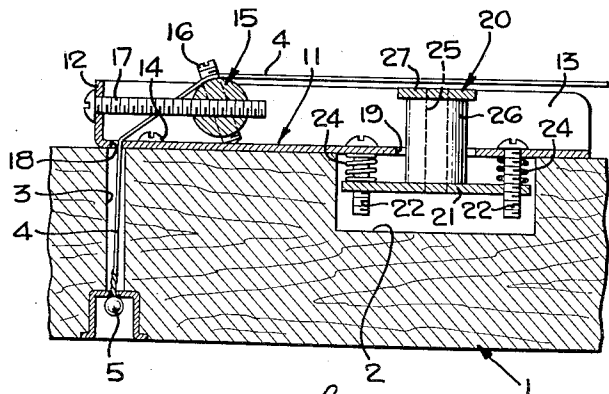

Fig. 3.

CLARENCE L. FENDER,
INVENTOR.

BY *Lyons*
ATTORNEYS

UNITED STATES PATENT OFFICE

2,573,254

COMBINATION BRIDGE AND PICKUP ASSEMBLY FOR STRING INSTRUMENTS

Clarence L. Fender, Fullerton, Calif.

Application January 13, 1950, Serial No. 138,305

6 Claims. (Cl. 84—1.16)

1

My invention relates to combination bridge and pickup assemblies for string instruments, and included in the objects of my invention are:

First, to provide a device of this class which is particularly suitable for electrically amplified guitars or similar musical instruments and which incorporates a novel sectional bridge permitting individual adjustment of the strings.

Second, to provide a device of this class wherein the pickup unit may be accurately adjusted relative to the strings of the instrument.

Third, to provide on the whole, a compact assembly which although economical of manufacture and installation is particularly dependable and effective in operation.

With the above and other objects in view as may appear hereinafter, reference is made to the accompanying drawings, in which:

Figure 1 is a top view of a guitar incorporating my invention.

Figure 2 is an enlarged top or plan view of my combination bridge and pickup assembly, the adjacent portions of the guitar body being shown fragmentarily.

Figure 3 is a sectional view through 3—3 of Figure 2.

My invention is shown in conjunction with a guitar which involves a body 1. The body may be solid except for a recess 2 to receive a portion of the pickup unit and vertical holes 3 which receive the strings 4 of the instrument. The underside of the body 1 is provided with suitable anchor fittings 5 in which the ends of the strings are secured. The strings pass over my bridge and pickup assembly, to be described hereafter, and extend in a conventional manner over the neck 6 of the guitar and are conventionally secured to the head 7 thereof.

My bridge and pickup assembly includes a plate 11, preferably formed of sheet metal and provided with an end flange 12 and side flanges 13. The plate 11 is positioned over the recess 2 and holes 3 and is secured in place by screws 14.

Mounted on the plate 11 are three bridge members 15, which form the parts of a sectional bridge. Each bridge member 15 is in the form of a short cylinder adapted to underlie two strings 4. Each bridge member is provided near its extremities with diametrically extending elevation set screws 16 the lower ends of which protrude through the bridge member and bear against the plate 11. Each bridge member 15 is also provided with one tension set screw 17, which extends horizontally therethrough and is journaled in the end flange 12. The strings 4 pass

2

over their respective bridge members and enter the holes 3 through mating perforations 18.

The plate 11 is provided with a clearance slot 19 in registry with the recess 2. Mounted in the clearance slot 19 and extending particularly in the recess as well as projecting in the plate 11, is a pickup unit 20. The pickup unit includes a base plate 21 of nonmagnetic material mounted within the recess 2 and adjustably suspended from the plate 11 by screws 22. Surrounding the screws 22, between the plate 11 and the base plate 21, are coil springs 24. The base plate 21 supports upstanding permanent magnet armatures 25 adapted to be located in alignment with the strings 4 of the guitar. The armatures are surrounded by a solenoid coil 26. Suitable leads (not shown) electrically connect the solenoid coil to a conventional amplifier. The upper extremities of the armatures 25 are retained in a head plate 27, also of nonmagnetic material.

The pickup unit is preferably suspended by three screws, so positioned that the pickup unit may be tilted slightly either about an axis traversing the strings or about an axis parallel with the strings, so that each armature may be brought into the proper relationship with its corresponding string. Furthermore, it has been found desirable to set the pickup unit in acute angular relation with the strings rather than at right angles thereto.

It has been found advantageous to place the elevation set screws 16 into the bridge members 15 at an angle to the vertical, as shown best in Figure 3. Also, the bridge members are disposed, at sufficient distance from the end flange 12, and the tension set screws 17 are journaled sufficiently loosely in the end flange to allow the necessary elevation adjustment of the bridge members. It will be noted that each bridge member 15 may be tilted about the axis of the tension screw 17, so that one of the strings supported by the bridge member 15 may be adjusted differently than the other. It will be observed that by reason of the adjustment of the set screws 17, the distance between the length of the string may be adjusted for proper noting of the frets.

Having fully described my invention, it is to be understood that I do not wish to be limited to the details herein set forth, but my invention is of the full scope of the appended claims.

I claim:

1. A bridge assembly for stringed musical instruments, involving: a plate member adapted to be secured to the body of a stringed musical instrument and apertured to receive the ends of

3

the strings thereof; a plurality of bridge bars underlying said strings; means for individually raising and lowering said bridge bars relative to said plate; and means for individually adjusting said bridge bars axially with respect to said strings.

2. A combination bridge and pickup assembly for steel stringed musical instruments, involving: a plate member adapted to be secured to the body of a stringed musical instrument and apertured to receive the ends of the strings thereof; a plurality of bridge bars underlying said strings; means for individually raising and lowering said bridge bars relative to said plate; means for individually adjusting said bridge bars axially with respect to said strings; and a magnetic pickup unit disposed under said strings adjacent said bridge bars.

3. A combination bridge and pickup assembly for steel stringed musical instruments, involving: a plate member adapted to be secured to a body of a stringed musical instrument and apertured to receive the ends of the strings thereof; a plurality of bridge bars underlying said strings; means for individually raising and lowering said bridge bars relative to said plate; means for individually adjusting said bridge bars axially with respect to said strings; a magnetic pickup unit supported by said plate adjacent said bridge bars; and means for adjusting the spacing of said unit relative to said strings.

4. The combination with a stringed musical instrument wherein a plurality of strings are anchored in a body structure of a bridge assembly, involving: a bridge bar disposed between the body structure and each pair of strings adjacent the anchored ends thereof; means adjacent the extremities of said bridge bars to alter the elevation of each extremity thereof independently relative to said body structure; and means for individually adjusting said bridge bars longitudinally relative to said strings.

5. The combination with a stringed musical instrument wherein a plurality of strings are

4

anchored in a body structure, of a bridge and pickup assembly, involving: a bridge bar disposed between the body structure and each pair of strings adjacent the anchored ends thereof; means adjacent the extremities of said bridge bars to alter the elevation of each extremity thereof independently relative to said body structure; means for individually adjusting said bridge bars longitudinally relative to said strings; and a pickup unit including elements sensitive to vibration of said strings, and means for adjusting the position of said sensitive elements relative to said strings.

6. The combination with a stringed musical instrument wherein a plurality of strings are anchored in a body structure of a bridge assembly, involving: a plate member secured to said body structure and apertured to receive said strings, said plate having an upright flange and defining a clearance opening; a pickup unit mounted in said clearance opening and including sensitive elements disposed in proximity to said strings, and means for adjusting said pickup unit about two axes to place said sensitive elements in predetermined relation with said strings; a bridge bar disposed between said plate and each pair of strings adjacent the string apertures of said plate; means adjacent the extremities of said bridge bars to alter the elevations thereof relative to said body structure; and means anchored in the flange of said plate for individually adjusting said bridge bars longitudinally relative to said strings.

CLARENCE L. FENDER.

REFERENCES CITED

The following references are of record in the file of this patent:

UNITED STATES PATENTS

Number	Name	Date
2,025,875	Loar	Dec. 31, 1935
2,087,106	Hart	July 13, 1937
2,152,783	Beauchamp	Apr. 4, 1939